



## Eagle Sun Systems Thermo-miser Drainback Tank Specifications

### Inner Tank (DB & DX Models):

- Stainless Steel construction from type 304 alloy
- Seams and fittings are Inert Gas Arc welded
- Connection fittings are ¾" female, NPT
- Each tank includes a vertical sight gauge with ½" female, NPT fittings, and diptube

### Outer Jacket & Insulation (DB & DX Models):

- Rigid foam insulation poured and molded in place, 1" on sides and bottom, 1½" on top (R7.2 per inch)
- ABS plastic outer shell with ABS vacuum molded end caps
- Polyethylene moldings around all fittings

### Heat Exchangers (DX Models):

- Standard internal heat exchanger coils are finned copper tube
- Connections are ½" female NPT



Part Number	Description	Tank Capacity	Dry Weight	Height/ Diameter
DB-10SSC	10 Gallon Drainback Tank	9.8 gal	27 lbs	17.75" / 16"
DB-15SSC	15 Gallon Drainback Tank	14.7 gal	31 lbs	25" / 16"
DB-10SS-10XC	10 Gallon Drainback Tank w/ 10 ft <sup>2</sup> Heat Exchanger	9.5 gal	37 lbs	20" / 16"
DB-15SS-15XC	15 Gallon Drainback Tank w/ 15 ft <sup>2</sup> Heat Exchanger	14.1 gal	46 lbs	25" / 16"
DB-20SS-20XC	20 Gallon Drainback Tank w/ 20 ft <sup>2</sup> Heat Exchanger			

These incredible drainback tanks can be configured for use in a variety of ways ....

- As retrofit to an existing water heater
- As a complete new Solar DHW system

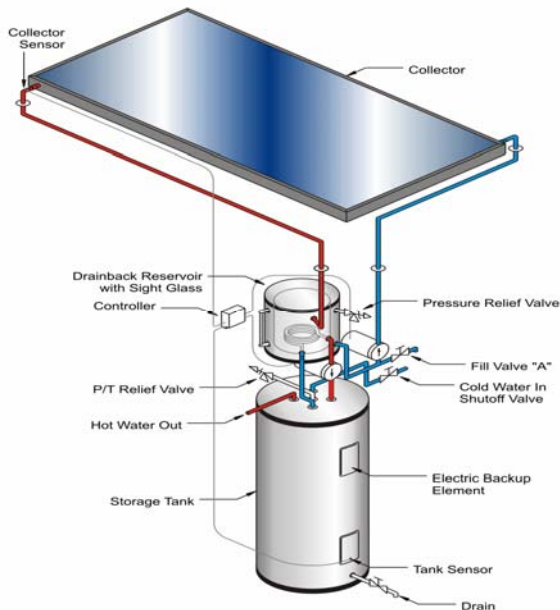

**DX Units can convert any standard tank to a solar water heater!**